

- **SURFACE MOUNT AND DIP PRESSURE SENSORS LOW-COST PACKAGED DIE**

## DESCRIPTION

provides its two most popular pressure sensor die in surface mount dual in-line package (SO-16) configuration. All parts in these series are uncompensated high-performance die mounted in an injection-molded package designed for surface mounting.

These packaged sensor die provide a way for OEM manufacturers to incorporate pressure sensors at costs close to raw die prices, without the need to handle, attach, or wire bond silicon sensor die.

Options include pressure range, absolute or gage configuration, and a choice of cap configurations. The result is a versatile product line suitable for a wide range of OEM applications.

The low-pressure series (model **SM5470**) incorporate Silicon Microstructures unique low-pressure die to achieve high performance in pressure ranges from 0.15 PSI full-scale to 3 PSI full-scale in gage and differential configuration.

The model **SM5430** comes in gage, differential, and absolute versions for pressure ranges from 5 PSI to 100 PSI.

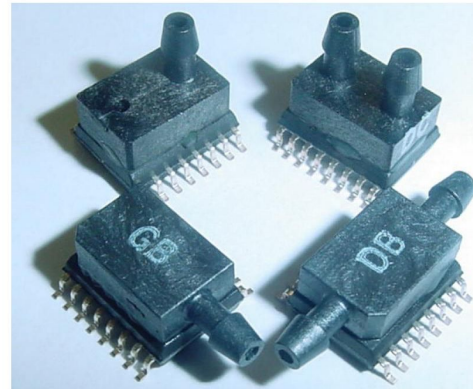

## FEATURES

- Low pressure (from 0-0.15 to 0-100 PSI FS)
- Easy to Use
- Compact and Light-weight
- High-performance, Stable Silicon Chip and Package
- Easily Embedded in OEM Equipment
- High-volume, Low Cost

## APPLICATIONS

- Altimeters
- Barometric Correction
- Tire Gauges
- Digital Pressure Gauges
- Environmental Monitoring
- Appliances
- Consumer and Sports
- HVAC
- Medical Instrumentation and Monitoring
- Pressure Differential and Flow Monitoring
- Hand-held Gauges

**Now Available in  
Tape and Reel**

# SM5430/SM5470

## CHARACTERISTICS FOR SM5430/SM5470 - SPECIFICATIONS

All parameters measure at 5V excitation at room temperature, unless otherwise specified.

### All Models

Parameter		Min.	Typ.	Max.	Units	Notes
Excitation Voltage		0	5.0	10.0	V	
Excitation Current		0	1.5	3.0	mA	
Offset	SM5470	-75	-30	+25	mV	
	SM5430	-50	0	+50	mV	
TC Span		-15	-19	-24	%FS/100°C	1
TC Resistance		33	28	25	%/100°C	1
Bridge Impedance		2.7	3.3	4.0	kΩ	
Operating Temp		-40		85	°C	
Storage Temp		-55		125	°C	

### SM5430 Standard Pressure Series

Span (FS Range), PSI (kPa)	Min.	Typ.	Max.	Units	Notes
5 (34)	75	100	125	mV	3
15 (103)	105	145	175	mV	3
30 (207)	115	165	195	mV	3
60 (414)	115	180	220	mV	3
100 (689)	115	200	250	mV	3
Linearity	-0.2	± 0.07	+0.2	%FS	4
TC Offset	-5	-1	+5	%FS/100°C	1
Burst Pressure	>5X			Rated FS Pressure	2

### SM5470 Low Pressure Series Only

Span (FS Range), PSI (kPa)	Min.	Typ.	Max.	Units	Notes
0.15 (1.03)	25	50	85	mV	3
0.30 (2.07)	25	50	85	mV	3
0.80 (5.52)	25	50	85	mV	3
1.50 (10.3)	25	50	85	mV	3
3.00 (20.7)	25	50	85	mV	3
Linearity	-0.3	± 0.1	+0.3	%FS	4
TC Offset		± 12		%FS/100°C	1
Burst Pressure	15X			Rated FS Pressure	2

Notes:

1. Measured from 0 to 70°C
2. Sensor die will survive pressure specified for all ranges. Maximum package pressure is 150 PSI.
3. Measured at 5V, constant voltage excitation
4. Defined as best-fit straight line (BFSL); for 0.3 PSI full-scale, linearity is ± 0.5%FS. For 0.15 PSI full-scale, linearity is ± 2.5%FS.

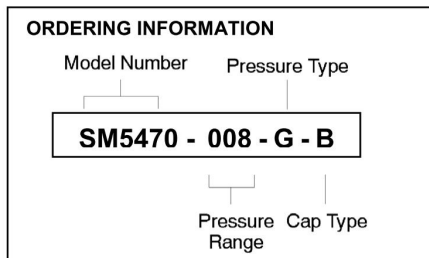

#### Pressure Type

- A: Absolute (except 5470)
- G: Gauge
- D: Differential

#### Available Cap Type

- B: Horizontal Barbed port(s)
- C: Vertical Barbed port(s)

#### Std. Pressure Ranges

PSI	5430
5	005
15	015
30	030
60	060
100	100

#### Low Pressure Ranges

PSI	5470
0.15	001
0.30	003
0.80	008
1.50	015
3.00	030

## Pin Out -- SM5430/SM5470

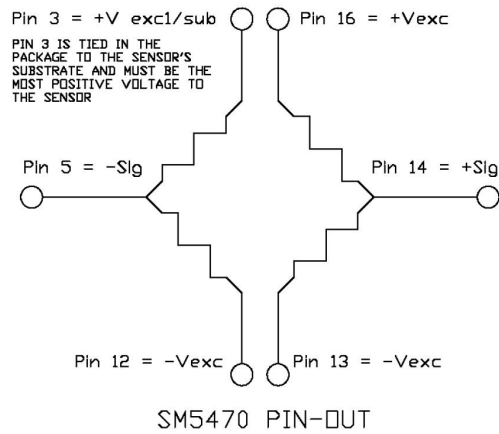
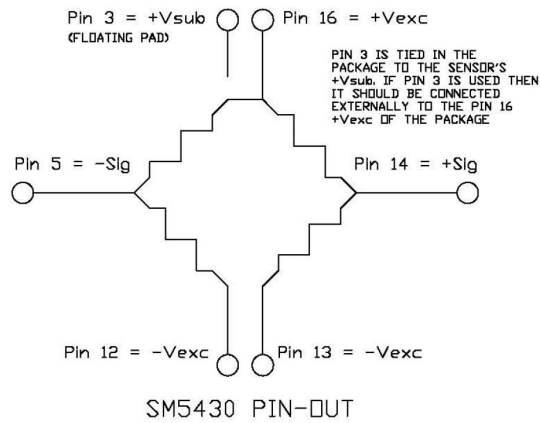

# SM5430/SM5470

## B- Horizontal Barb Configuration

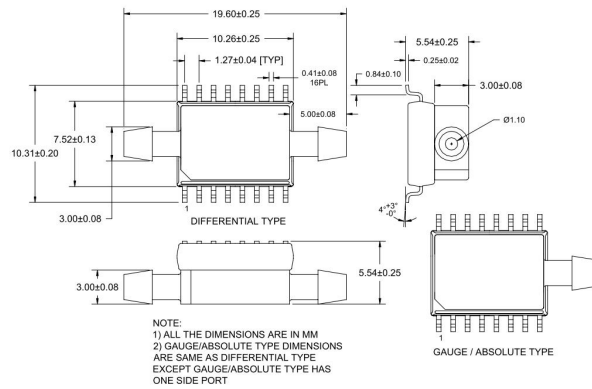

## C- Vertical Barb Configuration

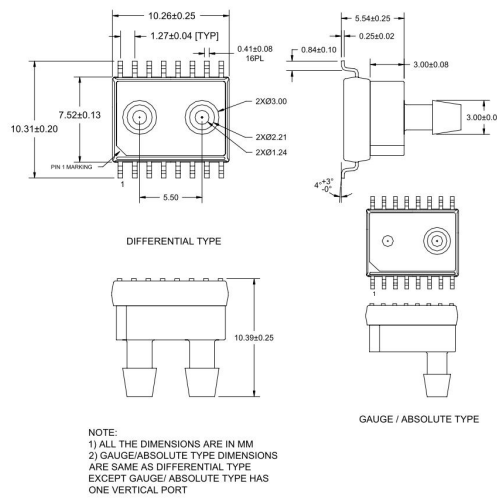

Dimensions (in millimeters) -- SM5430/SM5470